

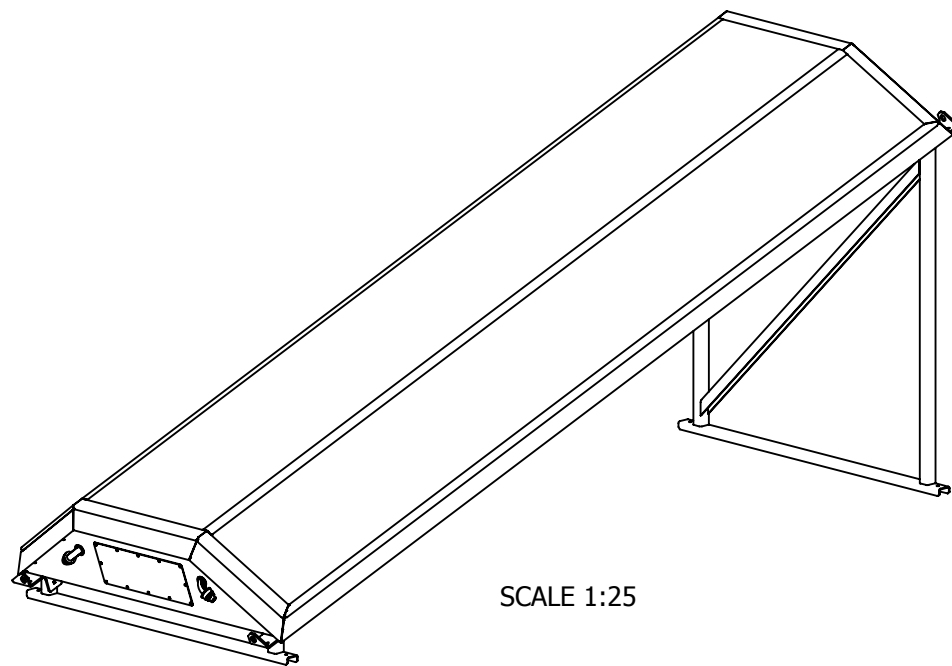

THIS DOCUMENT AND THE DATA DISCLOSED HEREIN OR WHEREWITH IS NOT TO BE REPRODUCED, USED, OR DISCLOSED IN WHOLE OR IN PART TO ANYONE WITHOUT THE PERMISSION OF CHROMASUN INC.

NOTES: UNLESS OTHERWISE SPECIFIED

1. SUPPORT LEGS ARE MADE FROM ALUMINUM TUBE AND CHANNEL WELDED TOGETHER
2. COLLECTOR WEIGHS 220 lbs (100 kg) WITHOUT SUPPORT LEGS

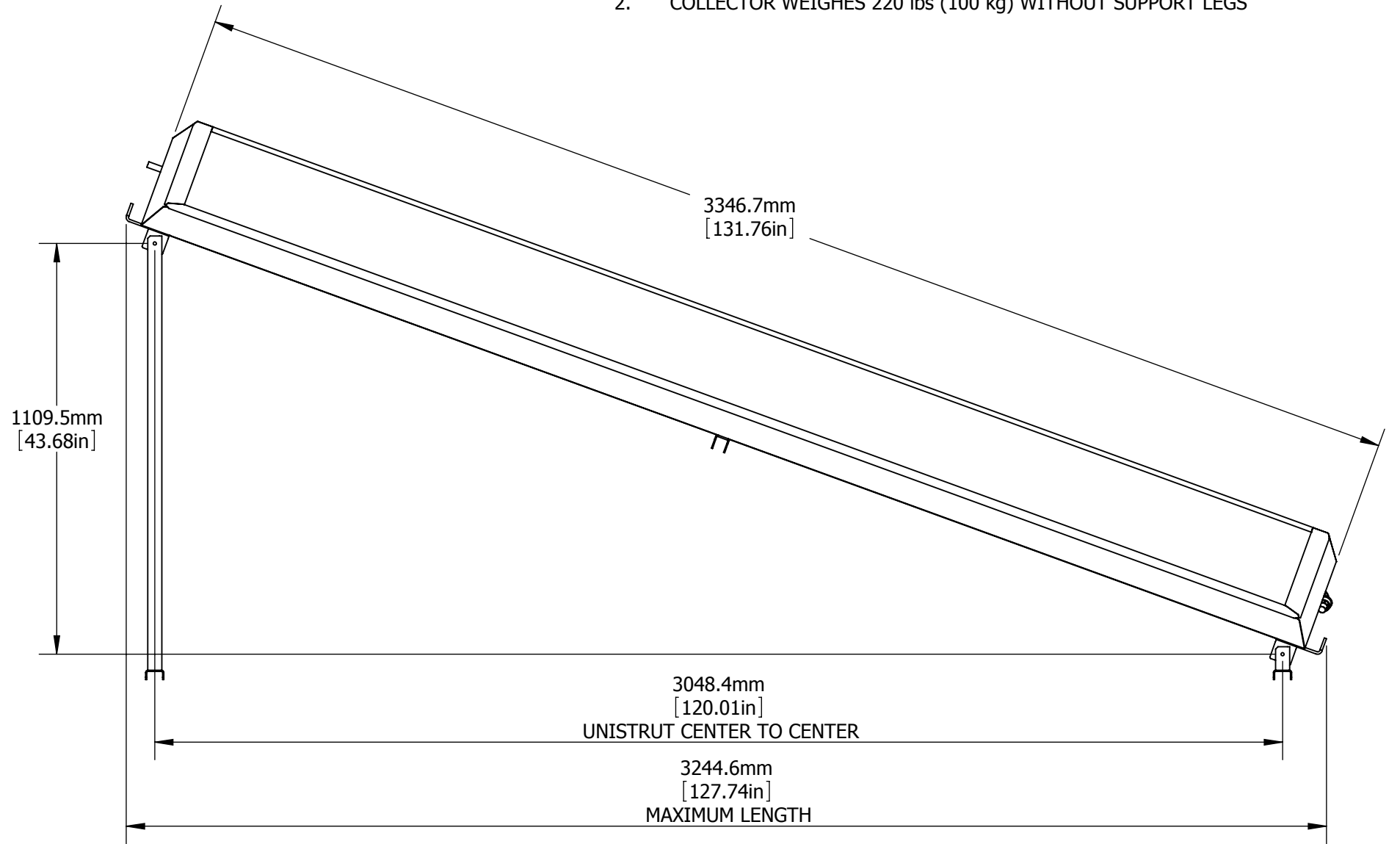
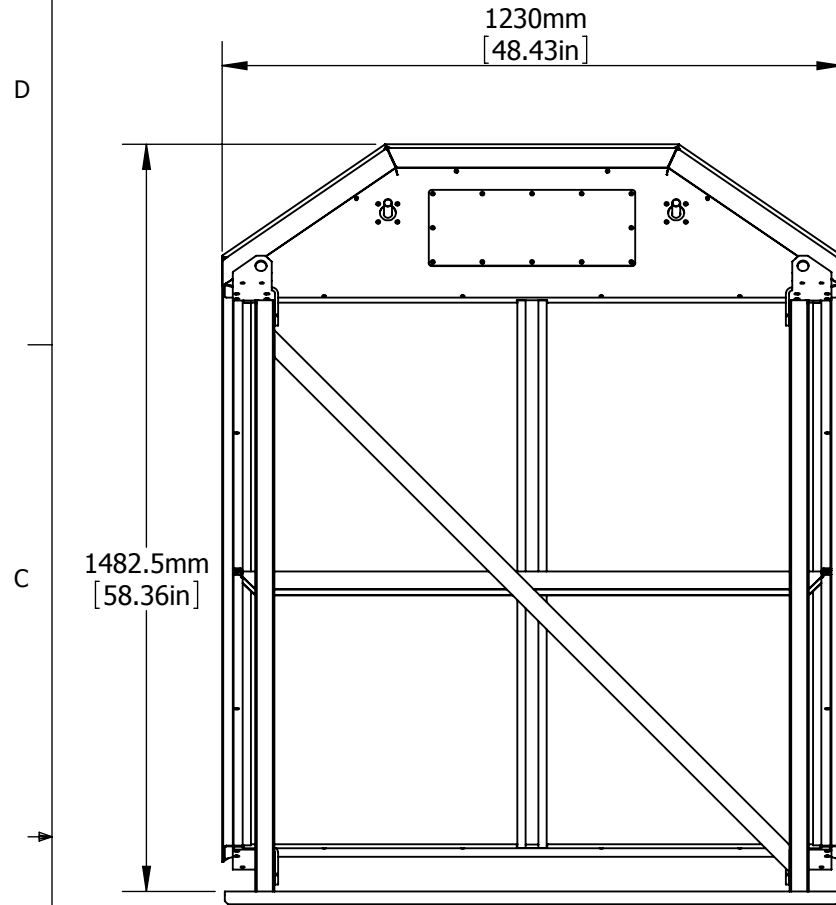

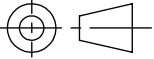
|   |  |   |   |
|---|--|---|---|
| UNLESS OTHERWISE SPECIFIED<br>DIMENSIONS ARE IN MILLIMETERS<br><br>TOLERANCES<br>X = ±0.3    X.XX = ±0.05<br>X.X = ±0.1    X* = ±0.5    | DIMENSIONS AND TOLERANCING<br>PER ASME Y14.5M-1994 |   |  <b>CHROMASUN INC</b><br>1050 N 5th STREET<br>SAN JOSE, CA 95112 |
|   | DRAWN<br>DD  |   |   |
| THIRD ANGLE PROJECTION<br><br>DO NOT SCALE DRAWING | CHECKED<br>MBG                                     |   |   |
| MATERIAL  | WEIGHT   | <b>MCT TOP LEVEL ASSEMBLY</b>           |   |
| SOLIDWORKS FILE<br>MCT_Top_Level_Roof_Mount_ASM   | SIZE<br><b>B</b>                                   | DWG NO.<br>MCT_Top_Level_Roof_Mount_ASM | REV   |
|   | SCALE<br>1:15                                      | DATE<br>10-Aug-11                       | SHEET<br>1 OF 1   |